

PFB300S

Wall Mount Bracket



Features

- Material: Aluminum
- Wall Mount Bracket
- Neat & Integrated design

Specifications

| Model | PFB300S |
|-----------------------|----------------------------------|
| General | |
| Material | Aluminum |
| Dimension (W x H x D) | 115mmx 160mm x 228mm |
| Pipe Thread | G1 1/2" |
| Operating Temperature | -40°C ~60°C |
| Humidity | 0~90% RH |
| Load Bearing | 3.0Kg |
| Weight | 0.49Kg |
| Applicable Model | Please see "Accessory Selection" |

PFB300S

Dimensions (mm)

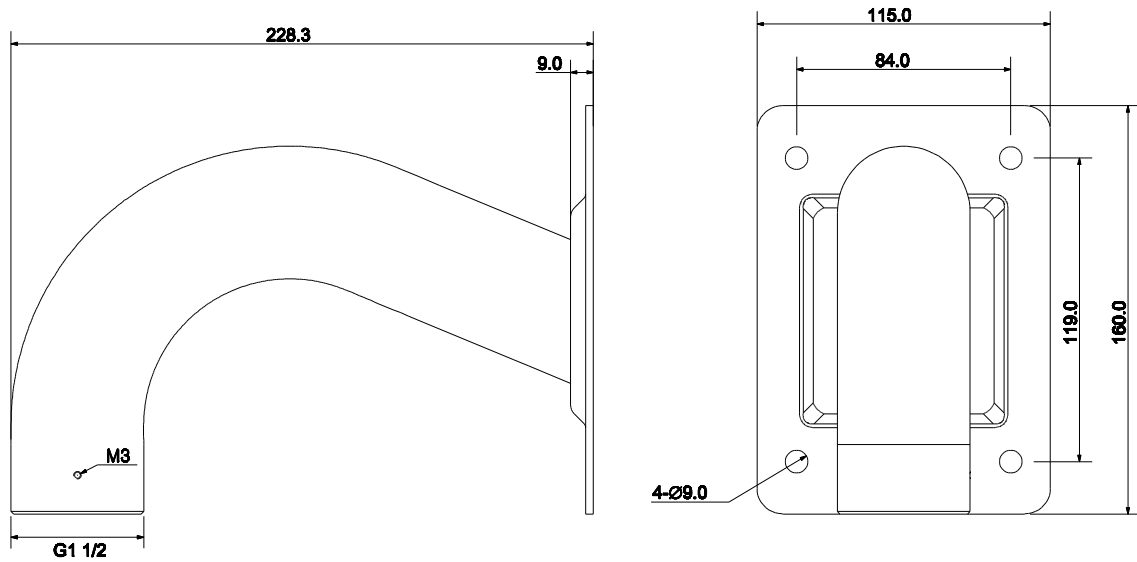

Application

